

Horizontal Surfaces

An excerpt from the *Dimension Stone Design Manual*,
Version VIII (May 2016)



**Produced and Published by the
Marble Institute of America
380 East Lorain St. Oberlin, Ohio 44074
Telephone: 440-250-9222
Fax: 440-774-9222
www.naturalstoneinstitute.org**

© 2016

All rights reserved. No part of this document may be reproduced or transmitted in any form or by means electronic or mechanical, including photocopy, recording, or by an information storage and retrieval system, without written permission from the Natural Stone Institute.

HORIZONTAL SURFACES

1.0 INTRODUCTION

1.1 Installation Methods. Stone paving can be installed by several methods. Consideration should be given to the various features of each method in making a selection for a specific installation. See illustrations of installation examples at the close of this section.

1.2 For additional information, refer to Chapter 13, INSTALLATION - GENERAL INFORMATION.

2.0 DESIGN CRITERIA

2.1 Class of usage establishes the abrasion resistance a stone requires to withstand the foot traffic requirements of the project. This is determined according to the ASTM C241/C 1353 test for abrasion resistance as measured by abrasive hardness (H_a). There are three classes of usage for stone flooring:

2.1.1 Light Traffic class is reserved for residential use where there is relatively little traffic and/or shoes are not always worn. Stone must have a minimum H_a of 6.0.

2.1.2 Moderate Traffic class is reserved for residential entranceways and small commercial installations. Foot traffic is less than 50 persons/minute. Stones must have a minimum H_a of 7.0

2.1.3 Heavy Traffic class is reserved for commercial installations (banks, shopping malls, train or bus stations, etc). Foot traffic is over 50 persons/minute. Minimum H_a is 10.0 for general areas, increasing to 12.0 for stairways, elevator halls, and other concentration areas. Exterior paving should always have a minimum H_a of 12.0.

2.1.4 It must be noted that these classifications are for the stone's abrasion resistance only. The stone's finish (polished, honed, thermal, etc.) will wear with traffic. Polished finish on stones with abrasion indices ≤ 20.0 are not suitable for most moderate and any heavy-traffic areas. Thermal finish is recommended for exterior paving.

2.1.5 Stone with high abrasion resistance (≥ 20.0) will generally maintain a polished surface in foot traffic areas. Stones with lesser abrasive indices are likely to abrade in service, and generally perform better if supplied in honed finish.

2.1.6 Limitations. If several varieties of stone are used together, care should be taken to ensure that the abrasive hardness (H_a) of the stones is similar. Proper testing (ASTM C241 or ASTM C1353) should be performed on each stone variety. If the abrasion resistance of either stone is < 20.0 , then the difference in abrasion resistance between the stone shall be ≤ 5.0 . This can be ignored when using stones with abrasion resistances ≥ 20.0 , since the resultant wear will be very slight.

2.2 Physical Property Values. Final design should always be based on specific property values of the stone to be used. These values may be obtained from the Stone Supplier. When reliable physical property data is not available from the supplier, re-testing of the stone should be considered.

2.3 Hollow Sound. Because of the weight and consequent difficulties in handling large-sized pavers, it is impossible to avoid an occasional "hollow" sound found in some stone units after installation.

2.3.1 Reasons for hollow sounds include:

2.3.1.1 A hollow sound may indicate that insufficient bonding of the paver exists, although it is not necessarily a reliable test.

Other influences can cause a hollow sound from a properly bonded paver.

2.3.1.2 Hollow sounds may be acoustical effects rather than bonding problems.

2.3.1.3 Air may be entrapped in either the setting bed or slab, causing one part of the floor to sound differently than another.

2.3.1.4 Separation or crack-isolation membranes installed between a slab and the setting bed may alter the sound report.

2.3.1.5 The elevation or composition of the subsurface may be irregular, causing one part of the floor to sound differently than another.

2.4 Width of Joints between Stones. Joints between stones should be of sufficient width to ensure that the grout being used can be placed at the bottom face of the stone and properly compacted within the joint.

2.4.1 Typical joint widths are:

2.4.1.1 Exterior Stone Pavement Installation: Minimum 1/4", preferably 3/8". Joints of 1/2" or larger are frequently required for large unit size installation.

2.4.1.2 Interior Stone Flooring Installation: Minimum 1/16", preferably 1/8". Joints of 1/4" or larger are frequently required for large unit size installation.

2.4.1.3 Joints of 1/2" to 1" are frequently required for installing stones with split, or "snapped" edges.

2.4.1.4 Stone units with "cleft" or other non-planar surface finishes generally require larger joints to minimize perceived lippage. Joint widths of 3/4" or 1" are not uncommon in these cases.

2.4.1.5 Joints of stone with an arris or chamfer will appear wider than its actual dimension when filled.

2.4.2 IN NO CASE SHOULD NATURAL STONE BE INSTALLED WITH TIGHT JOINTS

2.4.3 Where vertical surfaces meet horizontal paving, the joint should be filled with an elastomeric sealant in lieu of grout. These joints should be at least 3/8" in width, and continue through the stone assembly, all the way down to the substrate or backing (membranes may remain continuous). For joint depths greater than 3/8", backer rod is required. It is recommended that the horizontal surface go under the vertical surface.

2.4.4 Movement Joints are also required in fields of paving. Reference ANSI A108.01 section 3.7 and ANSI A108.02 section 4.4 for guidance on movement joint location.

2.4.5 Movement Joints: In addition to field and abutment to vertical surface requirements for movement joints in stone work, any expansion or construction joints in the substrate will need to carry completely through the stone installation assembly.

2.4.6 Wash and dry backs and edges of all pavers prior to installation.

3.0 MINIMUM THICKNESS

3.1 Suggested minimum thicknesses for stone walking surfaces:

3.2 Exterior Stone Pavers, Pedestrian Traffic: 1 1/4".

3.3 Exterior Stone Pavers, Vehicular Traffic: Is best determined by engineering analysis, but is generally 3" or thicker.

3.4 Interior Residential Stone Flooring: 3/8".

3.5 Interior Commercial Flooring, light duty: 3/8".

3.6 Interior Commercial Flooring, Heavy Duty/High Traffic: ¾", or 1¼" pending stone variety selection.

3.7 Note: Large stone unit sizes, specific loading/traffic requirements may dictate the use of greater thicknesses than those listed above.

4.0 LIPPAGE

Tolerances for allowable lippage can be found in Chapter 22 on Tolerances.

4.1 Allowable lippage is an installation tolerance, and is additive to the inherent warpage of the stone unit.

4.2 This lippage will not be attainable in flamed, cleft, or otherwise textured finishes. In those installations, joint width should be increased to limit perceived lippage, and in some cases joints as wide as ¾" may be required.

4.3 This degree of accuracy may not be achievable with extremely large format stone pavers, in which case larger than typical joint widths are recommended to minimize perceived lippage.

5.0 Slips and falls may be caused by inadequate available friction or due to a sudden change in available friction. For example, a spilled beverage or other contaminant may reduce available friction in a given area. Because of this, the maintenance of a floor is an important factor in its ability to provide a safe walking surface. Local building codes normally take precedence over other regulatory agencies. Natural stone used for paving provides an adequate available static coefficient of friction for human ambulation when supplied with an appropriate finish and properly maintained. Proper maintenance includes prompt cleanup of spills and correcting other conditions that can cause a

sudden reduction in a floor's static coefficient of friction. Aftermarket products are available for application on natural stones to increase available friction if required. Such products must be applied and maintained according to manufacturer's recommendations.

6.0 MEMBRANES

The use of membranes to improve system performance is common in the design of stone walking surface installations.

6.1 Always comply with the membrane manufacturer's written instructions regarding the applicability and installation of the membrane product.

6.2 Common types of membranes and their intended contribution to the system performance are discussed below:

6.2.1 Cleavage Membranes. Cleavage membranes are used in thick-bed installations below a reinforced mortar bed to intentionally prevent the bond between the stone setting system and the substrate slab, allowing independent movement (free floating) of the stone and setting system. Cleavage membranes can be either sheet applied or liquid applied.

6.2.2 Crack Isolation Membranes. Crack Isolation membranes are used to isolate the stone from minor in-pane cracking of the substrate surface in thin-set applications. Crack Isolation membranes can be sheet applied, trowel applied, or liquid applied and must meet ANSI A118.12.

6.2.3 Uncoupling Membranes. Uncoupling membranes are sheet applied, and geometrically configured to provide a small airspace which accommodates lateral flexibility between the tile and the substrate, reducing the transfer of stresses to the thin-set stone installation system.

6.2.4 Waterproof Membranes.

Waterproof membranes are used to prevent the migration of liquid water. These membranes can be sheet applied, sheet metal, or liquid applied. In many cases these membranes are installed by other trades and must meet ANSI A118.10.

7.0 TECHNICAL DATA

7.1 Each stone variety used for exterior stone paving should conform to the applicable ASTM standard specification and the physical requirements contained therein. The specification for each stone type follows:

7.1.1 Granite: ASTM C615, Standard Specification for Granite Dimension Stone

7.1.2 Limestone: ASTM C568, Standard Specification for Limestone Dimension Stone

7.1.3 Marble: ASTM C503, Standard Specification for Marble Dimension Stone

7.1.3.1 Soundness Classification of “A” or “B” is recommended; although some marbles with lesser soundness can be considered if waxing, sticking, filling, cementing, and reinforcing are properly done.

7.1.4 Quartz-Based Stone: ASTM C616, Standard Specification for Quartz-Based Dimension Stone

7.1.5 Serpentine: ASTM C1526, Standard Specification for Serpentine Dimension Stone

7.1.6 Slate: ASTM C629, Standard Specification for Slate Dimension Stone

7.1.7 Soapstone: No ASTM Standard exists at this time

7.1.8 Travertine: ASTM C1527, Standard Specification for Travertine Dimension Stone

8.0 GEOGRAPHIC METHODS

Some installation methods and materials are not recognized and may not be suitable in some geographic areas because of local trade practices, building codes, climatic conditions, or construction methods. Therefore, while every effort has been made to produce accurate guidelines, they should be used only with the independent approval of technically qualified persons.

During construction, the General Contractor shall protect all stone from staining and damage.

EXTERIOR PAVING SYSTEMS

1.0 PRODUCT DESCRIPTION

1.1 Basic Use. Exterior paving for plazas, promenades, and similar applications.

1.2 Fabrication. Stone paving units are precut and prefinished to dimensions specified on shop drawings, and are delivered to the job site ready to install.

1.3 Abrasion Resistance. See Section in Introduction.

1.4 Finishes. Abrasive, natural cleft, thermal, and rough sawn finishes are recommended for exterior paving.

1.5 Colors. Any of the commercially available varieties are suitable.

1.6 Sizes. Size and thickness should be based on:

1.6.1 Flexural Strength (Ref: ASTM C880) of the stone

1.6.2 The unsupported span or anticipated deformation of the bedding system.

1.6.3 The anticipated load.

1.6.4 Standard thicknesses of 1¼", 1⅝", and 2" or greater may be required.

1.7 Movement Joints. All stone paving systems shall include adequate movement joints. Refer to ANSI 108.1 and TCNA EJ 171 for movement joint location and design.

1.8 Traffic after Installation. After the stone paving has been installed, the General Contractor must keep all traffic off the floors for at least 48 hours. No rolling or heavy (greater than pedestrian) traffic should be permitted on newly installed stone surfaces for at least two weeks after the floor has been grouted or caulked.

2.0 INSTALLATION

2.1 Mortar Bed Bonded to Concrete Subsurface

2.1.1 Preparatory Work. Concrete slabs to receive bonded mortar beds, shall fulfill the following requirements:

2.1.2 Slope as required shall occur in the slab so as to maintain an even depth or thickness of the mortar bed.

2.1.3 Concrete Slab shall have a textured surface similar to a fine broom finish and shall be free of curing compounds or any other foreign materials that would inhibit an adequate bond of the mortar bed to the slab.

2.1.4 Concrete Slabs that require additional work to achieve these requirements such as grinding, feathering, patching or scarifying are considered as non-compliant with Industry Standards for stonework until remedial work has been completed by others.

2.1.5 Method. Stone paving should be installed in a full mortar bed consisting of one part portland cement and from four to five parts sand. Minimum thickness of a mortar bed is 1¼". The recommended thickness is 2". A bond coat of portland cement paste or other approved material (slurry) is recommended.

2.1.6 Joints. The joints may be pointed with suitable mortar or grout, or left entirely open to receive a resilient filler strip and approved sealant.

2.1.7 Reinforcing. Reinforcing of the mortar bed is recommended for beds of 2" depth or greater and shall be specified by the design professional. See TCNA F121 and NOTE for exterior uses.

2.2 Mortar bed separated from concrete slab. This method is used where the concrete slab may be problematic such as anticipated differential movement between the slab and the stone assembly. Other factors

which favor selection of this installation method include:

2.2.1 Cracks in the slab that may transfer through a bonded system.

2.2.2 Contamination of the slab that may be impractical to remove.

2.2.3 Capillary moisture issues exist.

2.2.4 Where cold or control joints in slab do not align with stone grid modules.

2.2.5 Where an unbondable membrane exists.

2.2.6 In these situations, the slab will require remedial treatment commensurate with the severity of the problem. These options usually involve a membrane of some type and as such the mortar bed cannot be bonded to the substrate. As with the bonded mortar bed systems, slope and tolerance of the slab shall be such as to maintain an even thickness of the bed. Movement joint requirements will also remain the same; however, the membrane may remain continuous.

2.2.7 The mortar bed must be reinforced in any unbonded installation system as specified by the design professional.

2.3 Pedestal Supported Systems

2.3.1 Preparatory Work. Adequate slope for surface drainage must be provided in rough concrete slab. Before being installed, all stone must be clean and free of foreign matter of any kind.

2.3.2 Method. Stone slabs (pavers) shall be set on bricks, plastic pods, or mortar spots of one part portland cement and from three to five parts sand, at or near the corners with the joints left open for drainage (see illustration at the close of this section).

2.3.3 Flexural Strength. In a pedestal supported pavement system, the stone unit is a structural member that carries the live and dead loads back to the pedestals. Paver

thickness, span, flexural strength, and appropriate safety factors must be considered in the design.

2.3.4 Open Joints. The joints in this system are left open, allowing water to flow below the stone units to be collected by the drainage system.

2.3.5 Advantages of this system include the elimination of the requirement to slope the stone surface to a drain, since the drainage is accomplished below the pedestrian deck, and the ease of removal and replacement of the pavers to facilitate servicing of the drainage system below.

2.4 Sand Bed Method

2.4.1 Preparatory Work. Excavate unsuitable, unstable, or unconsolidated subgrade material and compact the area that has been cleared. Fill and level with densely graded crushed stone aggregate suitable for subbase material, or as otherwise directed by Specifying Authority.

2.4.2 Method. Place bedding course of sharp, normal weight limestone screening or concrete sand to a depth of approximately 1½" leveled to grade. Compact bedding course parallel to finish grade and tamp.

2.4.3 Stone pavers shall be laid upon the bedding course in successive courses. Every course of pavers shall be laid true and even and brought to grade by the use of wood mallets or similar tools, and shall be laid parallel to the base line. After the pavers are laid, the surface shall be swept and inspected. Cover surface with a wood board approximately 3" thick, 12" wide, and 6' long, and tamp with an approved tamper. Do all tamping immediately after laying pavers and do not allow tamper to come in contact with pavers. Broom sand into joints, tamping sand in joints to ensure full bedding around perimeter of stone.

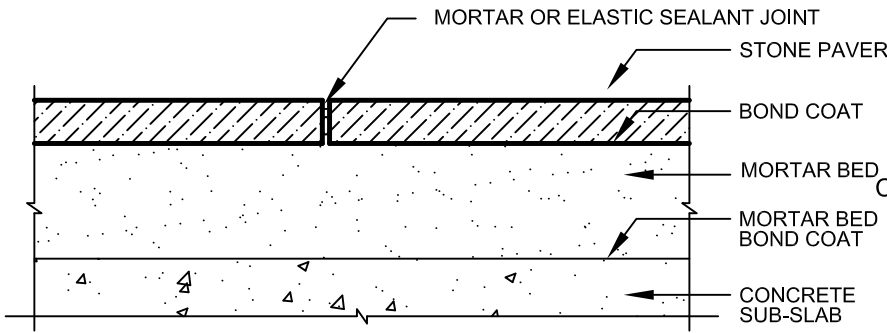

1 MORTAR BED WITH BOND COAT

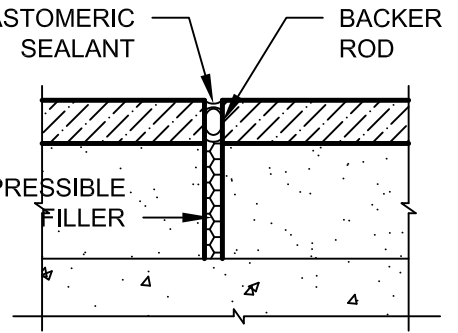

1A MOVEMENT JOINT

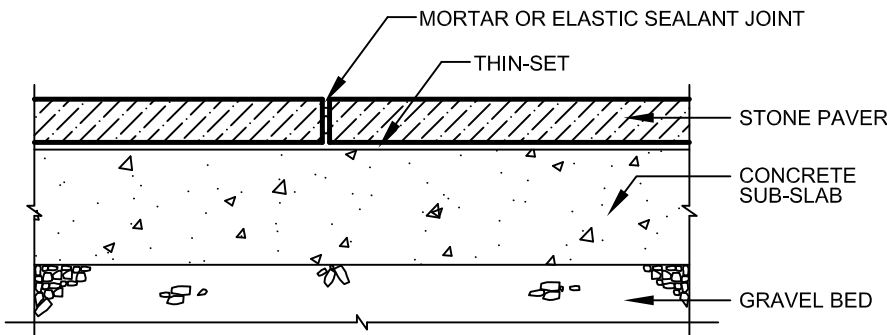

2 MORTAR BED WITH THINSET

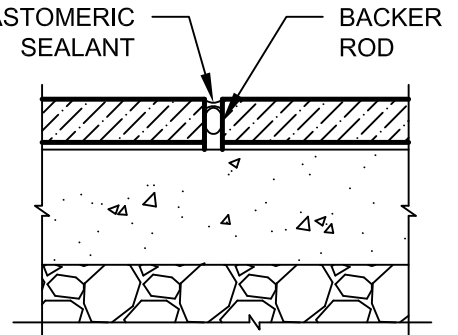

2A MOVEMENT JOINT

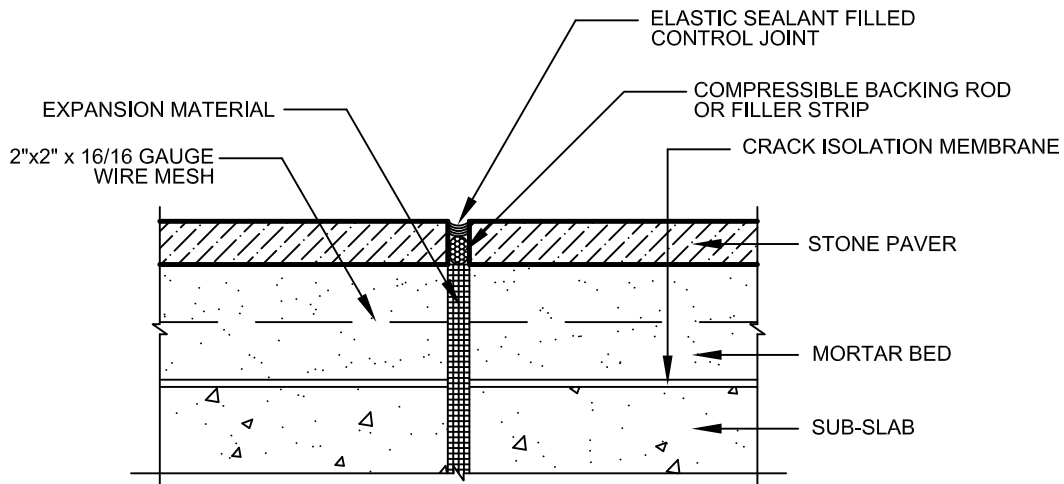

3 FULL MORTAR BED WITH MEMBRANE AND EXPANSION JOINT

NOTE: IT IS NOT THE INTENT OF THIS MANUAL TO MAKE EXPANSION, CONTROL, OR MOVEMENT JOINT RECOMMENDATIONS FOR A SPECIFIC PROJECT. THE SPECIFYING AUTHORITY MUST DESIGN AND LOCATE EXPANSION, CONTROL, AND MOVEMENT JOINTS ON THE CONSTRUCTION DOCUMENTS.



380 East Lorain Street • Oberlin, OH 44074 USA
Tel: (440) 250-9222 • www.marble-institute.com

REV	DATE
0	Aug 2006
1	Oct 2006
2	Dec 2009

EXTERIOR STONE PAVING

MIA DIMENSION STONE DESIGN MANUAL VIII

DRWG NO: 14-D-1

SCALE:
3" = 1'-0"

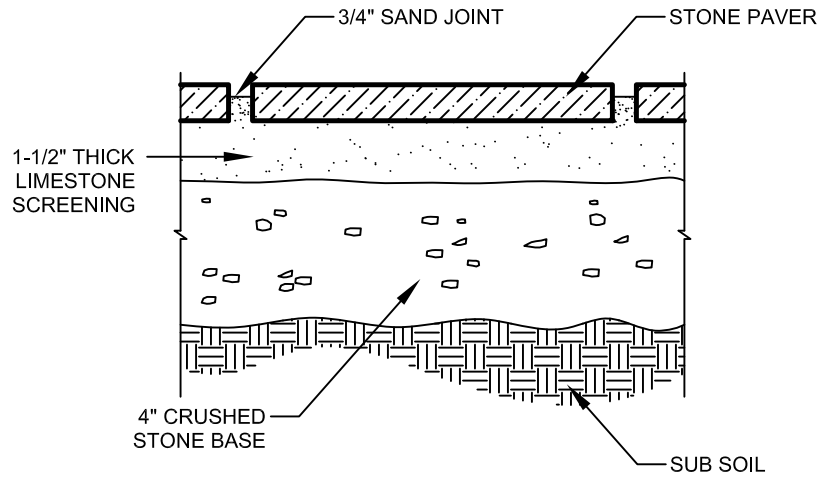

1 STONE PAVERS SET IN SAND BED
 Scale: 3" = 1'-0"

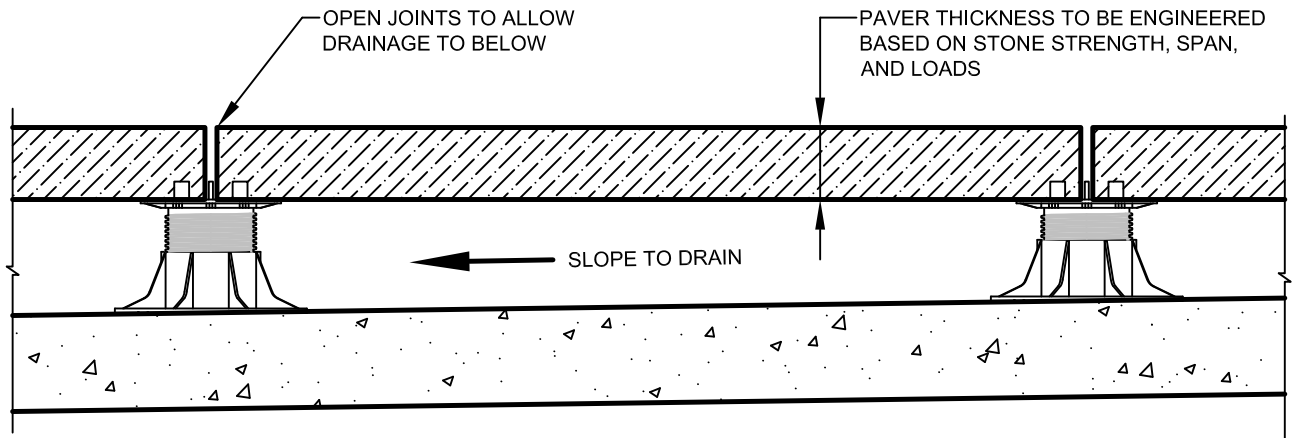

2 PEDESTAL SUPPORTED STONE PAVERS
 Scale: 1/2" = 1'-0"



380 East Lorain Street • Oberlin, OH 44074 USA
 Tel: (440) 250-9222 • www.marble-institute.com

REV	DATE
0	Aug 2006
1	Oct 2006
2	Dec 2009

EXTERIOR STONE PAVING

MIA DIMENSION STONE DESIGN MANUAL VIII

DRWG NO: 14-D-2

SCALE:
As Noted

INTERIOR STONE FLOORING SYSTEMS

1.0 INTRODUCTION

1.1 Installation Methods. Interior stone flooring can be installed by several methods. Consideration should be given to the various features of each method in making a selection for a specific installation. (See Data Sheet Installation section and illustrations of installation examples at the close of this section).

1.2 Abrasion Resistance. See Introduction Section. (Note: abrasion resistance does not measure values for coefficient of friction or slip resistance.)

2.0 RELATED COMPONENTS

2.1 TCNA Details. Because natural stone tiles can be installed in certain thin-bed setting systems in the same manner as ceramic tiles, the current “Handbook for Ceramic Tile Installation” by the Tile Council of North America may be referred to for details. A list of details from this manual endorsed by the MIA is included in Chapter 13 of this manual.

2.2 Stone Abuts Softer Floor Material. Where stone abuts softer flooring materials, a stone threshold or metal edge protection strip may be used. This will help prevent edge chipping caused by impact.

2.3 Grout. Sanded or unsanded grout, or nonstaining sealant, can be used as joint filler. If sanded grout is used, mask the face of the stone tile before filling the joints to avoid scratching of the stone surface.

2.4 Stones Sensitive to Moisture and Alkalinity. Stone suppliers shall identify stones that are adversely affected by moisture and alkalinity.

2.5 Setting Bed. White Portland cement with low alkali content is recommended for light colored stone.

2.6 Bond Mortar. White bond mortar is recommended for light colored stone.

2.7 Hollow Sound. Refer to the section in introduction portion of this chapter.

2.8 Traffic after Installation. After the stone flooring has been installed, the General Contractor must keep all traffic off the floors for at least 48 hours. No rolling or heavy (greater than pedestrian) traffic should be permitted on newly installed stone flooring surfaces for at least two weeks after the floor has been grouted.

2.9 Sealing. Reference Maintenance and Restoration Section of the DSDM for MIA position on sealers.

2.10 For additional information, refer to Chapter 13, INSTALLATION - GENERAL INFORMATION.

2.11 Geographic Methods. Some installation methods and materials are not recognized and may not be suitable in some geographical areas because of local trade practices, building codes, climatic conditions, or construction methods. Therefore, while every effort has been made to produce accurate guidelines, they should be used only with the independent approval of technically qualified persons.

3.0 PRODUCT DESCRIPTION

3.1 Basic Use. As interior flooring for commercial, institutional, and residential use.

3.2 Abrasive Hardness. Reference Introduction Section

3.3 Fabrication. Stone flooring units are precut and prefinished to dimensions specified on shop drawings, and delivered to the job site

ready to install. Alternatively, stone flooring units may be field cut or field modified at the installation site.

3.4 Finishes. Polished, honed, abrasive, thermal, sanded, and natural cleft.

3.5 Colors. Most of the commercially available varieties are suitable.

4.0 INSTALLATION METHODS

Interior stone flooring is installed by one of the following methods.

4.1 Mortar Bed Bonded to Concrete Subfloor This method is used where the concrete sub-floor is not subject to excessive movement or deflection (Recommended for installation of larger pieces [slabs]).

4.1.1 Concrete to receive bonded mortar beds or direct bond of stone shall fulfill the following requirements:

4.1.1.1 Slope if required, shall occur in the concrete substrate so as to maintain an even depth or thickness of the mortar bed and/or bond mortar.

4.1.1.2 Concrete shall have a textured surface similar to a fine broom finish and shall be free of curing of curing compounds or any other foreign materials that would inhibit an adequate bond of the mortar bed or bond mortar to the concrete.

4.1.1.3 Undersides and edges of concrete slabs on grade shall have a suitable vapor barrier so as to prevent moisture intrusion into concrete.

4.1.1.4 Concrete that requires additional work to achieve these requirements such as grinding, feathering, patching or scarifying are considered as non-compliant with Industry Standards for stonework until remedial work is completed.

4.1.2 Limits of moisture vapor transmission shall be established by the stone supplier.

Testing and certification of compliance is the responsibility of the specifying authority.

4.1.3 Wash and dry backs and edges of pavers or tiles prior to installation.

4.1.4 A mortar bed consisting of one part portland cement to five parts sand is laid over the concrete subfloor to a nominal thickness of 1¼". Stone buttered uniformly with a cement paste bond coat are laid over the mortar bed and tamped into a true and level plane. Joints are grouted with a portland cement based grout or other approved material. (See Detail at the close of this section).

4.2 Mortar Bed Separated From Concrete Subfloor. This method is used where the concrete slab may be problematic such as anticipated differential movement between the slab and the stone assembly. Other factors that would favor the selection of this installation system include:

4.2.1 Cracks in the slab that may transfer through a bonded system.

4.2.2 Contamination of the slab that may be impractical to remove.

4.2.3 Capillary moisture issues exist.

4.2.4 Where cold or control joints in slab do not align with stone grid modules.

4.2.5 Where an unbondable membrane exists.

4.2.6 In these situations, the slab will require remedial treatment commensurate with the severity of the problem. These options usually involve a membrane of some type and as such the mortar bed cannot be bonded to the substrate. The requirement for unbonded mortar beds is that they be reinforced as specified by the design professional; usually with wire at the approximate center of the bed. As with the bonded mortar bed systems, slope and tolerance of the slab shall be such as to maintain an even thickness of the bed. Movement joint requirements will also remain

the same; however, the membrane may remain continuous.

4.3 Mortar Bed Separated From Wood Subfloor. This method is used where subfloor is subject to movement and deflection.

4.3.1 Mortar bed floats over subfloor and minimizes possibility of stone cracking from structural movement. An isolation membrane is laid over the sub-floor. A mortar bed consisting of one part portland cement to four to five parts sand with reinforcement specified by the design professional. Stone tiles are laid over the mortar bed and tamped into proper plane. Joints are later grouted with a portland cement based grout or other approved material. (See Detail D-3 at the close of this section).

4.4 Thin Bed Over Plywood Subfloor

4.4.1 This method should be used only in residential construction. The subfloor must be adequately designed to carry loads without excessive deflection. Subfloor must be level with a maximum variation of 1/8" in 10'-0", and a deflection not exceeding L/720. Cross-bridging or other reinforcement shall be used to limit differential deflection between adjacent framing members. Comply with all Manufacturers' written installation instructions. Apply mortar with flat side of trowel over an area that can be covered with tile while mortar remains plastic. Within ten minutes and using a notched trowel sized to facilitate the proper coverage, comb mortar to obtain an even setting bed without scraping the backing material. Key the mortar into the substrate with the flat side of the trowel. Back butter the stone tiles to ensure 95% contact with no voids exceeding 2 in² and no voids within 2" of tile corners on 3/8" tile. Back butter the stone tiles to ensure 80% contact with no voids exceeding 4 in² and no voids within 2" of tile corners on 3/4" or thicker material. All corners and edges of stone tiles must be fully supported and contact shall always be 95% in water-susceptible conditions.

Joints are later grouted with a portland cement based grout or other approved material.

4.5 Thin-Bed Portland Cement Mortar Over Concrete Substrate

4.5.1 This method is used when space for full mortar bed is not possible. Concrete subfloor should not be subject to excessive movement or excessive deflection. Subfloor must be level with maximum variation of 1/4" in 10'-0". Mortar bed is laid using a notched trowel over subfloor to a thickness of not greater than 3/32". Apply mortar with flat side of trowel over an area that can be covered with tile while mortar remains plastic. Within ten minutes and using a notched trowel sized to facilitate the proper coverage, comb mortar to obtain an even setting bed without scraping the backing material. Key the mortar into the substrate with the flat side of the trowel. Back butter the stone to ensure 95% contact with no voids exceeding 2 in² and no voids within 2" of tile corners on 3/8" tile. Back butter the stone tiles to ensure 80% contact with no voids exceeding 4 in² and no voids within 2" of tile corners on 3/4" or thicker material. All corners and edges of stone tiles must always be fully supported and contact shall always be 95% in water-susceptible conditions. Joints are later grouted with a portland cement based grout or other approved material. (See Detail at the close of this section).

4.6 Thin-Bed Mortar Over Cementitious Backer Units

4.6.1 This method should be used only in residential construction and per manufacturers' instructions. The subfloor must be adequately designed to carry loads without excessive deflection. The cementitious backer unit is considered to be a bonding layer only, and provides negligible structural contribution to the flooring system. Subfloor must be level with a maximum variation of 1/16" in 3'-0", and a deflection not exceeding L/720. Cross-bridging or other reinforcement shall be used to limit differential deflection between adjacent framing members. Apply mortar with flat side of trowel over an

area that can be covered with tile while mortar remains plastic. Within ten minutes and using a notched trowel sized to facilitate the proper coverage, comb mortar to obtain an even setting bed without scraping the backing material. Key the mortar into the substrate with the flat side of the trowel. Back butter the stone tiles to ensure 95% contact with no voids exceeding 2 in² and no voids within 2" of tile corners on 3/8" tile. Back butter the stone tiles to ensure 80% contact with no voids exceeding 4 in² and no voids within 2" of tile corners on 3/4" or thicker material. All corners and edges of stone tiles must be fully supported and contact shall always be 95% in water-susceptible conditions. Joints are later grouted with a portland cement based grout or other approved material.

5.0 HEATED FLOOR SYSTEMS

5.1 In frame construction, the plywood portion of the substrate must be a minimum of 1½" exterior glue plywood. Leave a gap between the plywood sheets for expansion. Install a cleavage membrane over the plywood.

5.2 Frame and Mortar Bed. Heated floor systems are generally proprietary in nature, and the manufacturer's installation guidelines shall be closely followed. Consider using a heat deflector on top of the membrane. The Heating Contractor should install the heating system per Manufacturer's recommendation. Fill cavity with a wire or portland mix so that the mortar bed covers pipes and is at least ¾" over the top of heating pipes, with a minimum bed thickness of 2½". Allow to cure for at least 30 days. This mortar bed thickness is necessary to dissipate heat to avoid damaging the stone by uneven heating. Follow applicable Data Sheet Installation methods listed previously, but first install a crack-suppression or uncoupling membrane according to Manufacturer's recommendation.

6.0 PLYWOOD SUBFLOORS

5.3 Refer to APA form No. E30 for plywood installation methods.

5.3.1 Plywood subfloors, including tongue-and-groove plywood, must be installed with a gap between the sheets to allow for expansion. Stagger all seams. All subfloor seams should occur over framing, with underlayment seams occurring approximately 25% into the span between framing members. Plywood should have the strength axis running perpendicular to the joist.

5.3.2 Plywood shall be APA underlayment, C-C plugged or plugged crossband grade.

5.3.3 Inner surfaces must be clean. Remove all sawdust and dirt before applying adhesive.

5.3.4 Use a construction adhesive, applying a 1/8" bead at 2" intervals. Apply adhesive in accordance with manufacturer's written directions.

5.3.5 Allow adhesive to cure per manufacturer's recommendations before beginning stone installation.

5.3.6 Place screws 6" on center in both directions.

5.3.7 Align strength axis of both subfloor and underlayment layers.

5.3.8 Always apply a double layer subfloor/underlayment, regardless of joist spacing.

5.3.9 Always use a crack suppression membrane in frame construction.

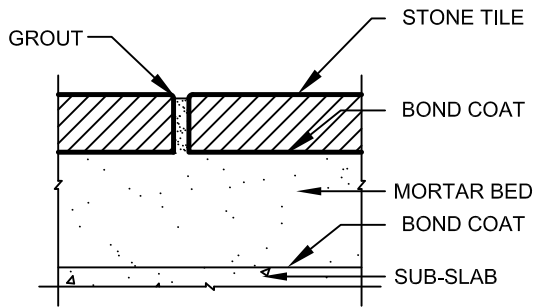

1 STONE TILE SET IN MORTAR BED

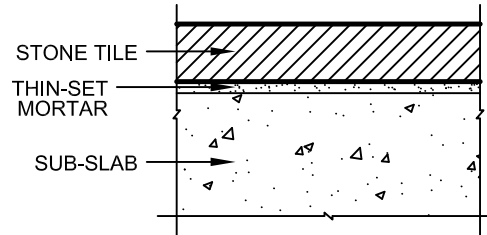

4 STONE TILE SET IN THIN-SET BED OVER CONCRETE SLAB

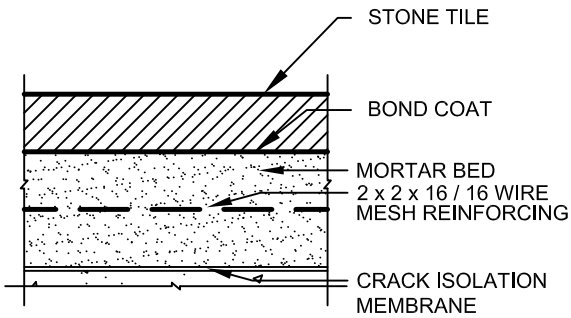

2 STONE TILE SET IN REINFORCED MORTAR BED

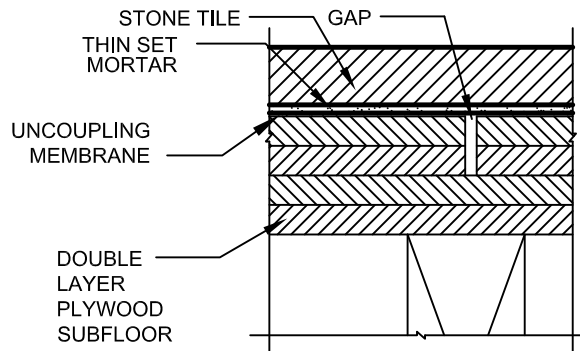

5 STONE TILE SET IN THIN-SET BED WITH UNCOUPLING MEMBRANE OVER WOOD FRAME

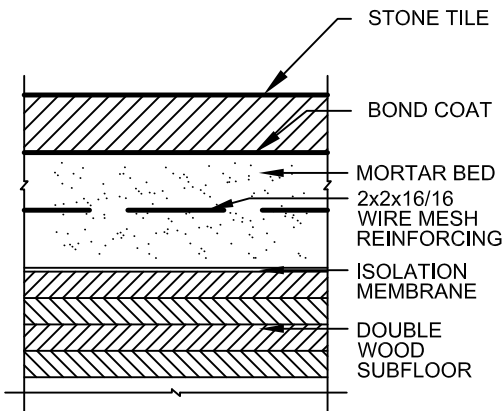

3 STONE TILE SET IN REINFORCED MORTAR BED OVER WOOD FRAME



380 East Lorain Street • Oberlin, OH 44074 USA
Tel: (440) 250-9222 • www.marble-institute.com

REV	DATE
0	Aug 2006
1	Oct 2006
2	Dec 2009

INTERIOR STONE FLOORING

MIA DIMENSION STONE DESIGN MANUAL VIII

DRWG NO: 14-D-3

SCALE:
3" = 1'-0"

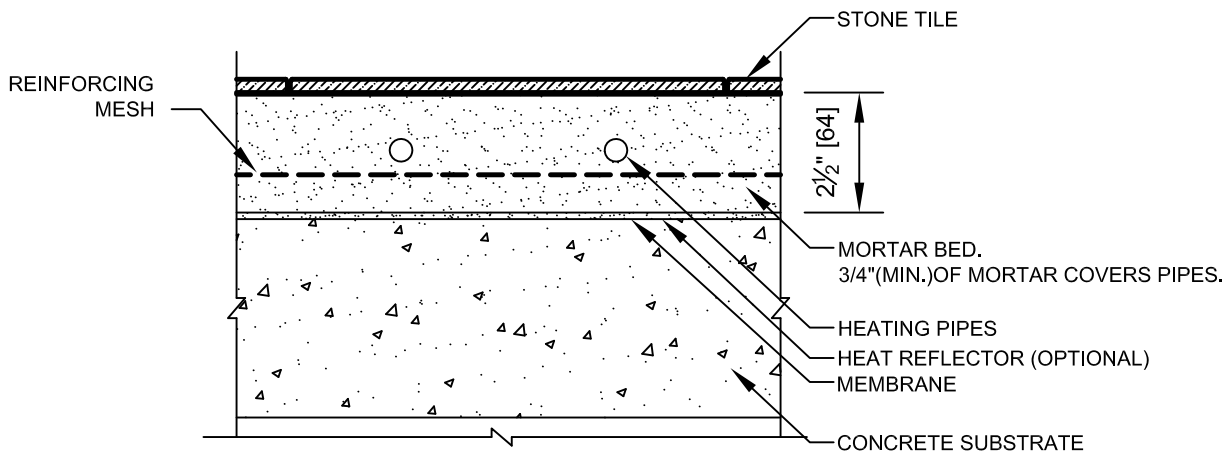

1 STONE TILE OVER HYDRONIC RADIANT HEAT SYSTEM WITH CONCRETE SUBSTRATE

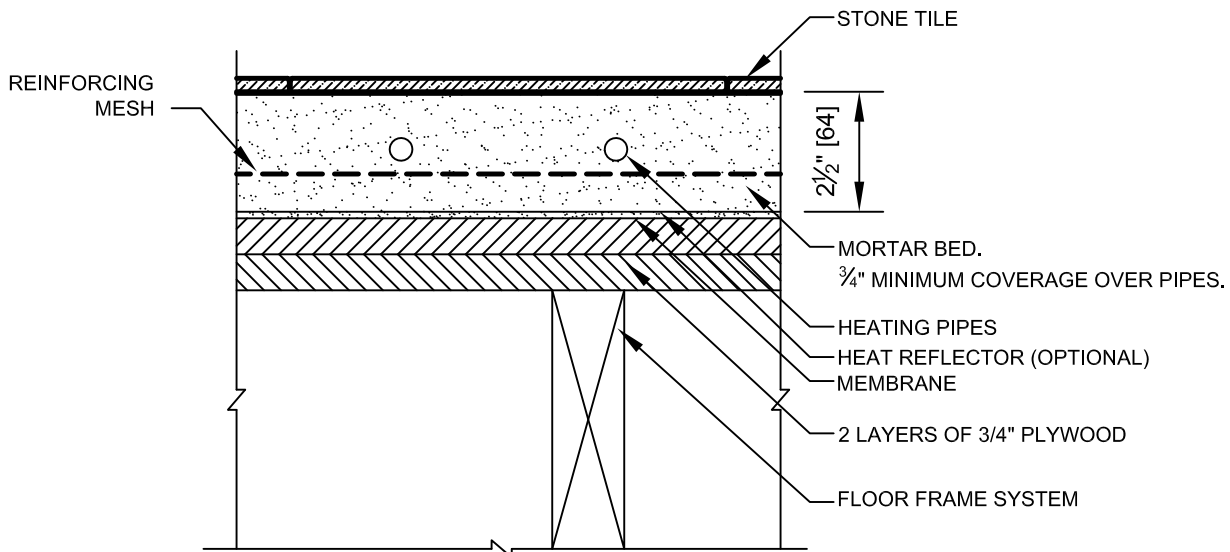

2 STONE TILE OVER HYDRONIC RADIANT HEAT SYSTEM WITH WOOD FRAME SUBSTRATE



380 East Lorain Street • Oberlin, OH 44074 USA
Tel: (440) 250-9222 • www.marble-institute.com

REV	DATE
0	Aug 2006
1	Oct 2006
2	Dec 2009

INTERIOR STONE PAVING
RADIANT HEAT DETAILS
MIA DIMENSION STONE DESIGN MANUAL VIII

DRWG NO: 14-D-4

SCALE:
3" = 1'-0"

HORIZONTAL SURFACES – STONE THRESHOLDS

1.0 INTRODUCTION

1.1 Installation Methods. Stone thresholds can be installed by several methods. Consideration should be given to the various features of each method in making a selection for a specific installation. (See Data Sheet Installation section and illustrations of installation examples at the close of this section).

2.0 DESIGN CRITERIA

2.1 Thresholds. By acting as a transitional piece between two different finished floor levels, thresholds permit the use of the conventional, thick-bed mortar method in rooms where it would not otherwise be possible. They also can be used with thin-set methods.

2.2 Abrasive Hardness. Care should be taken to ensure the abrasive hardness (H_a) of the varieties selected is a minimum of 12.0 as measured by ASTM C241. These values may be obtained from the Stone Supplier.

2.3 Stone Abuts Softer Floor Material. Where stone abuts softer flooring materials, stone thresholds or metal edge protection profiles may be used. This will help prevent chipping caused by impact.

2.4 Traffic after Installation. After the stone thresholds have been installed, the General Contractor must keep all traffic off the thresholds for at least 48 hours. No heavy traffic should be permitted on newly installed stone flooring surfaces for at least two weeks.

2.5 White portland cement is recommended as a setting bed for light-colored granite and marble. White portland cement

with a low alkali content is recommended for limestone.

2.6 Exposed edges may be eased, rounded, arrised or beveled. If instructions are not given as to type of edge required, Supplier will furnish according to industry standards.

2.7 For additional information, refer to Chapter 13, INSTALLATION - GENERAL INFORMATION.

2.8 Geographic Methods. Some installation methods and materials are not recognized and may not be suitable in some geographic areas because of local trade practices, building codes, climatic conditions, or construction methods. Therefore, while every effort has been made to produce accurate guidelines, they should be used only with the independent approval of technically qualified persons.

3.0 PRODUCT DESCRIPTION

3.1 Basic Use. Floor structural element that lies below a door or other entranceway.

3.2 Limitations. Only varieties having a minimum abrasive hardness (H_a) of 12.0, as measured by ASTM C241, are recommended.

3.3 Fabrication. Stone thresholds are precut and prefinished to dimensions specified on shop drawings, and delivered to the job site ready to install.

3.4 Finishes. Polished and honed.

3.5 Colors. Most of the commercially available varieties are suitable.

3.6 Sizes. Thicknesses of ½", ¾", and 1¼", or as specified.

4.0 TECHNICAL DATA

4.1 Each stone variety used for thresholds should conform to the applicable ASTM standard specification and the physical requirements contained therein. The specification for each stone type follows:

4.1.1 Granite: ASTM C615, Standard Specification for Granite Dimension Stone

4.1.2 Limestone: ASTM C568, Standard Specification for Limestone Dimension Stone

4.1.3 Marble: ASTM C503, Standard Specification for Marble Dimension Stone

4.1.4 Quartz-based Stone: ASTM C616, Standard Specification for Quartz-based Dimension Stone

4.1.5 Slate: ASTM C629, Standard Specification for Slate Dimension Stone

4.1.6 Serpentine: ASTM C1526, Standard Specification for Serpentine Dimension Stone

4.1.7 Soapstone: No ASTM Standard exists at this time

4.1.8 Travertine: ASTM C1527, Standard Specification for Travertine Dimension Stone

5.0 INSTALLATION

5.1 Methods. Stone thresholds may be installed using a cement mortar bed, epoxy mortar, or any of the thin-set mortar methods. (See detail illustrations at the close of this section).

5.2 100% coverage of mortar bed material between threshold and subfloor is recommended.

5.3 General Precaution. During construction, the General Contractor shall protect all stone from staining or damage.

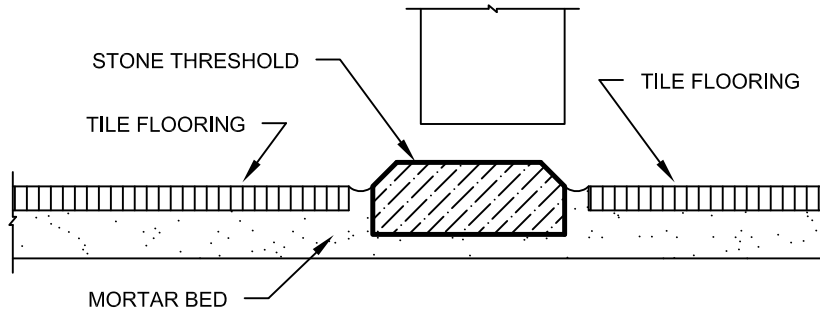

1 MEDIUM BED MORTAR METHOD

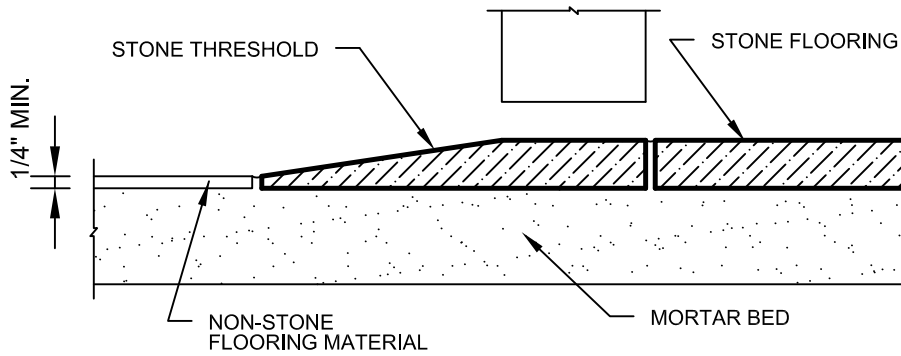

2 FULL MORTAR BED METHOD

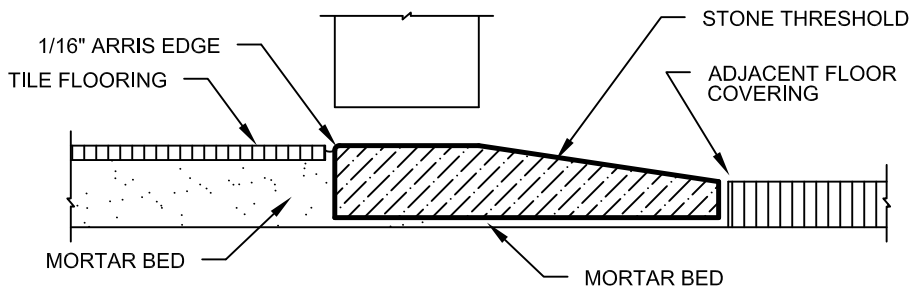

3 THIN-SET METHOD

NOTE: USE 100% COVERAGE OF BOND COAT MATERIAL BETWEEN THRESHOLD AND SUB-SLAB.

NOTE: Minimum Abrasive Hardness Of Threshold Material Should Be 12.0 (ASTM C241).



380 East Lorain Street • Oberlin, OH 44074 USA
Tel: (440) 250-9222 • www.marble-institute.com

REV	DATE
0	Aug 2006
1	Oct 2006
2	Dec 2009

STONE THRESHOLDS

MIA DIMENSION STONE DESIGN MANUAL VIII

DRWG NO: 14-D-5

SCALE:
6" = 1'-0"

NOTES:

HORIZONTAL SURFACES – STONE STAIR TREADS

1.0 INTRODUCTION

1.1 Installation Methods. Stone stair treads can be installed by several methods, each dependent upon the design detail. Consideration should be given to the various features of each method in making a selection for a specific installation. (See Data Sheet Installation section and illustrations of installation examples at the close of this section).

2.0 DESIGN CRITERIA

2.1 Final design should always be based on physical properties of the stone to be used. If the open-tread detail is planned utilizing the stone tread as a structural member spanning the stringers, the thickness should be developed by an Engineer based on the strength properties furnished by the Stone Supplier.

2.2 Slip Resistance. Slip resistant strips or filled grooves are recommended in heavy-traffic areas. These can be specified as shop fabricated or field installed per applicable code or building requirements.

2.3 Deflection. The backup for stone steps must be of limited ($<L/720$) deflection for installation of thin ($1\frac{1}{4}$ " or less) treads. If there is greater deflection, the thickness of the tread is determined by calculating the load and ensuring that the flexural strength (ASTM C880) of the stone is sufficient to resist the load, including a safety factor. In any event, the minimum recommended thickness is $1\frac{1}{4}$ " for treads and $\frac{3}{4}$ " for risers.

2.4 Traffic after Installation. After the stone treads have been installed, the General Contractor must keep all traffic off the treads for at least 48 hours. No heavy traffic should be

permitted on newly installed treads for at least two weeks.

2.5 Thin stone ($\frac{1}{2}$ " and under) treads and risers may be installed using a thin-set portland cement mortar bed over clean and level concrete subtreads or double layers of $\frac{3}{4}$ " plywood installed in opposite directions with $1/8$ " gaps between sheets. These types of applications will not withstand high impact or wheel loads. No overhang is permitted when stones of this thickness are used.

2.6 White portland cement is recommended as a setting bed for light-colored granite and marble. White portland cement with a low alkali content is recommended for limestone.

2.7 For additional information, refer to Chapter 13, INSTALLATION - GENERAL INFORMATION.

2.8 Geographic Methods. Some installation methods and materials are not recognized and may not be suitable in some geographical areas because of local trade practices, building codes, climatic conditions, or construction methods. Therefore, while every effort has been made to produce accurate guidelines, local building codes should be consulted for compliance.

3.0 PRODUCT DESCRIPTION

3.1 Basic Use. Horizontal top part of a step in a staircase.

3.2 Limitations. Only varieties having a minimum abrasive hardness (H_a) of 12.0 or more, as measured by ASTM C241, are recommended.

3.3 Finishes. Honed, polished, abrasive, thermal, and natural cleft for interior uses; rough, textured, abrasive, thermal, honed, and natural cleft for exterior uses.

3.4 Colors. Most of the commercially available varieties.

3.5 Sizes. Tread thicknesses of $\frac{3}{4}$ ", $1\frac{1}{4}$ ", and $1\frac{1}{2}$ " for interior uses. Thicknesses of $1\frac{1}{2}$ ", 2" and cubic (greater than 2") for exterior. Risers may be $\frac{3}{4}$ " or $1\frac{1}{4}$ " thick.

4.0 TECHNICAL DATA

4.1 Each stone variety used for stone stair treads should conform to the applicable ASTM standard specification and the physical requirements contained therein. The specification for each stone type follows:

4.1.1 Granite: ASTM C615, Standard Specification for Granite Dimension Stone

4.1.2 Limestone: ASTM C568, Standard Specification for Limestone Dimension Stone

4.1.3 Marble: ASTM C503, Standard Specification for Marble Dimension Stone (Exterior)

4.1.4 Quartz-based Stone: ASTM C616, Standard Specification for Quartz-based Dimension Stone

4.1.5 Slate: ASTM C629, Standard Specification for Slate Dimension Stone

4.1.6 Serpentine: ASTM C1526, Standard Specification for Serpentine Dimension Stone

4.1.7 Soapstone: No ASTM Standard exists at this time

4.1.8 Travertine: ASTM C1527, Standard Specification for Travertine Dimension Stone

5.0 INSTALLATION

5.1 Methods. Stone stair treads may be installed in a cement mortar bed, or in a thin-

set cement mortar bed, over a subread, or supported by stringers. (See detail illustrations at the close of this section).

5.1.1 100% coverage of mortar bed material between tread and subread is desirable.

5.1.2 Risers $\frac{3}{4}$ " or thicker must be anchored with wire or stainless steel strap anchors. If risers thinner than $\frac{3}{4}$ " are used, they may be installed using the thin-bed portland cement mortar method.

5.2 General Precaution. During construction, the General Contractor shall protect all stone from staining or damage.

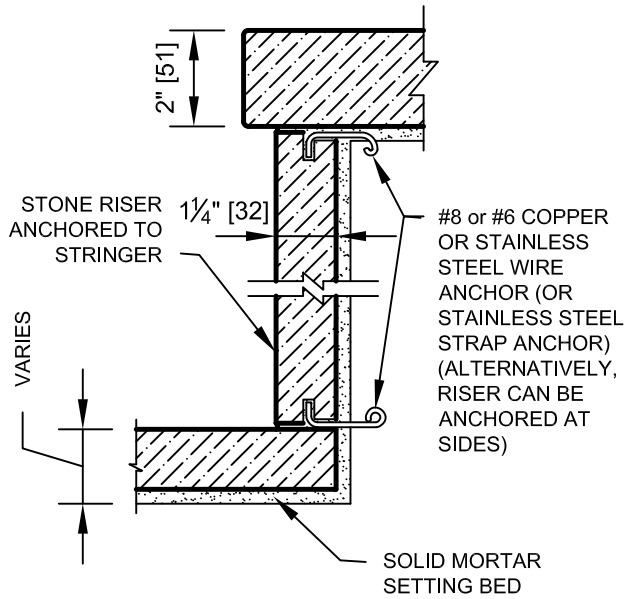

1 VENEERED STEP DETAIL
SCALE: 3" = 1'-0" (1:4)

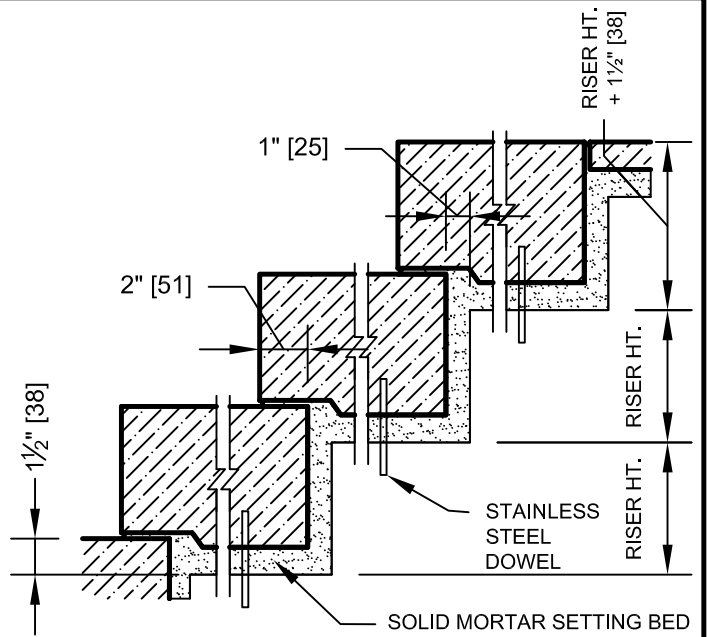

2 CUBIC STEP DETAIL
SCALE: 1/2" = 1'-0" (1:8)

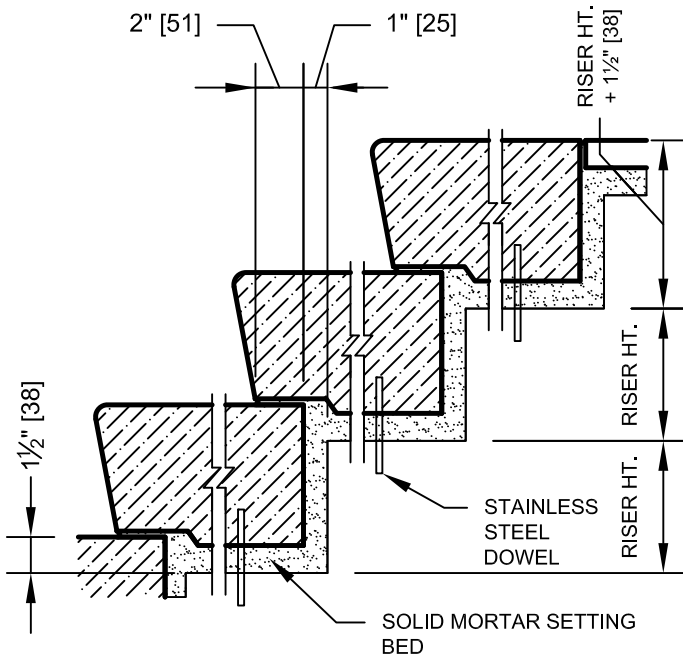

3 CUBIC STEP DETAIL
SCALE: 1/2" = 1'-0" (1:8)

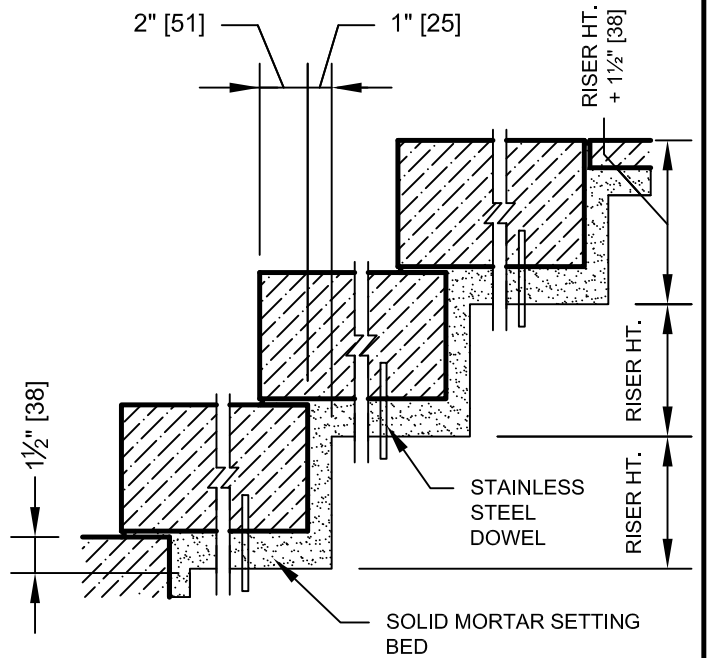

4 CUBIC STEP DETAIL
SCALE: 1/2" = 1'-0" (1:8)

NOTES: 1. A ROUGH OR TEXTURED FINISH IS RECOMMENDED FOR EXTERIOR USAGE.
2. MINIMUM ABRASION RESISTANCE OF 12.0 (TESTED PER ASTM C 241) IS RECOMMENDED FOR STONE TREADS.



380 East Lorain Street • Oberlin, OH 44074 USA
Tel: (440) 250-9222 • www.marble-institute.com

REV	DATE
0	Aug 2006
1	Oct 2006
2	Dec 2009

STONE STAIR TREAD DETAILS

MIA DIMENSION STONE DESIGN MANUAL VIII

DRWG NO: 14-D-6

SCALE:
As Noted

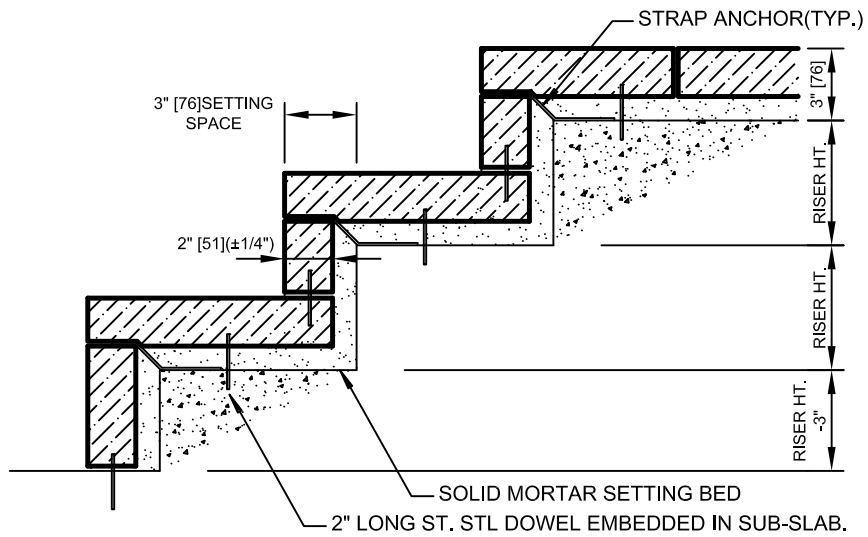

5 VENEERED STEP DETAIL

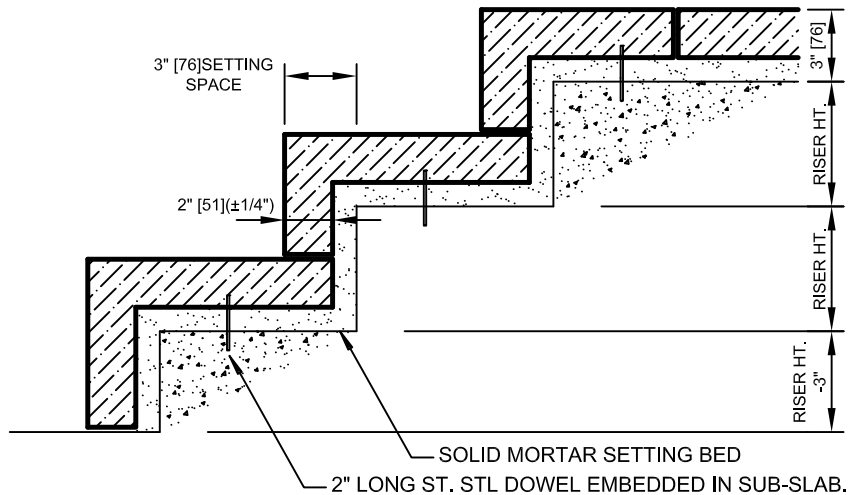

6 HOOKED STEP DETAIL

- NOTE: 1. A ROUGH OR TEXTURED FINISH IS RECOMMENDED FOR EXTERIOR USAGE.
 2. MINIMUM ABRASIVE HARDNESS OF 12.0 IS RECOMMENDED FOR STONE TREADS(ASTM C241).
 3. FABRICATION LABOR REQUIREMENTS COMMONLY MAKE DETAIL 6 A HIGHER COST ALTERNATIVE.



380 East Lorain Street • Oberlin, OH 44074 USA
 Tel: (440) 250-9222 • www.marble-institute.com

REV	DATE
0	Aug 2006
1	Oct 2006
2	Dec 2009

STONE STAIR TREADS

MIA DIMENSION STONE DESIGN MANUAL VIII

DRWG NO: 14-D-7

SCALE:
 1/2" = 1'-0"

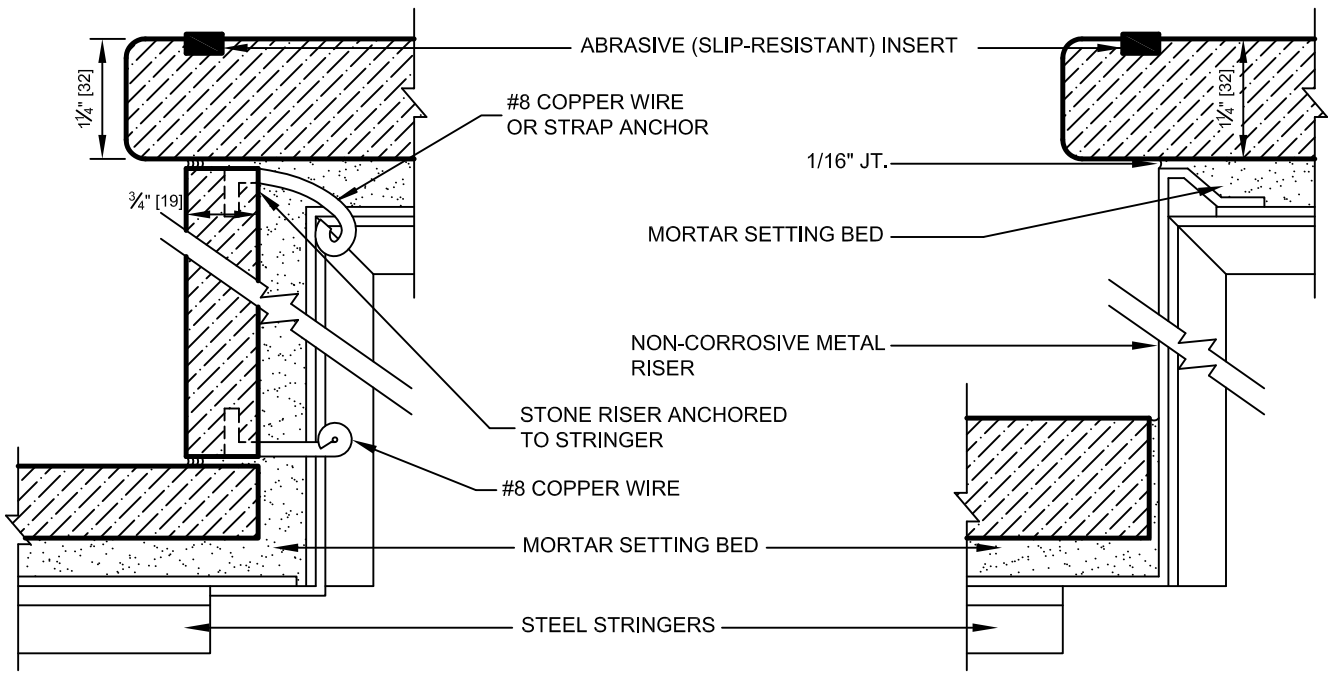

1 STEP DETAIL ON METAL PAN

2 STEP DETAIL ON METAL PAN

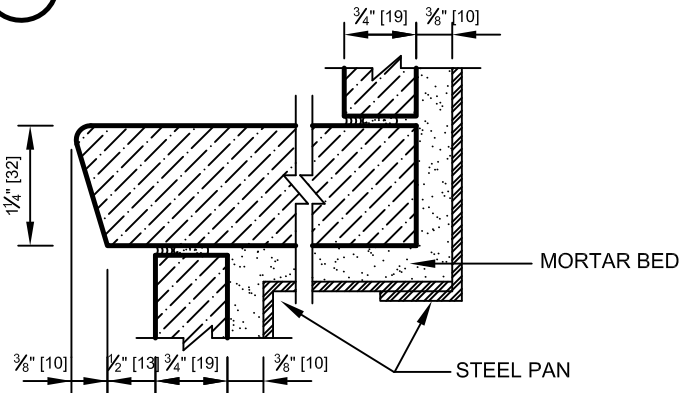

3 STEP DETAIL ON METAL PAN

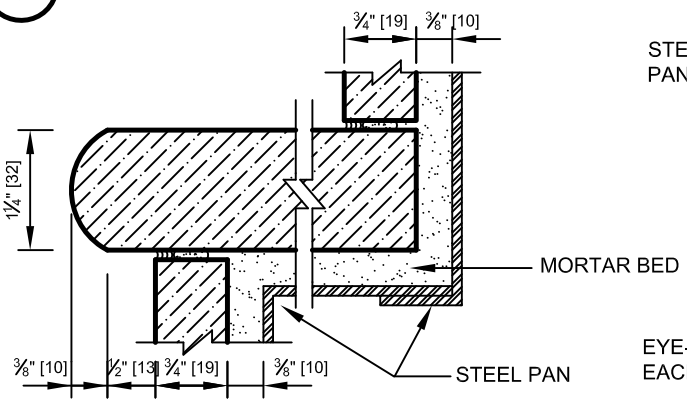

4 STEP DETAIL ON METAL PAN

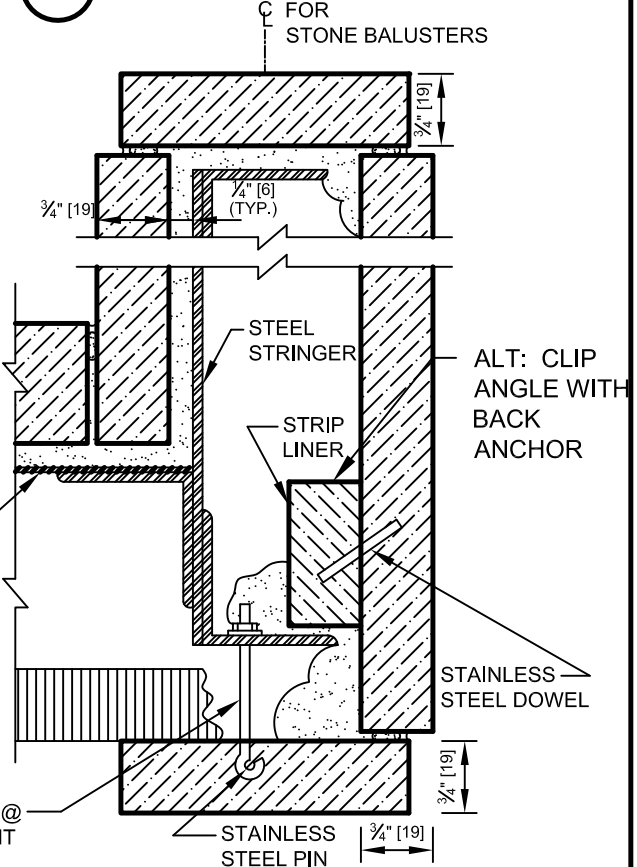

5 STEP DETAIL ON METAL PAN



380 East Lorain Street • Oberlin, OH 44074 USA
Tel: (440) 250-9222 • www.marble-institute.com

REV	DATE
0	Aug 2006
1	Oct 2006
2	Dec 2009

STONE STAIR TREADS/TYPICAL DETAILS
/INTERIOR TREADS

MIA DIMENSION STONE DESIGN MANUAL VIII

DRWG NO: 14-D-8

SCALE:
6" = 1'-0"

NOTES: